

MHP15HD

TRAILER MOUNTED BOOM LIFTS



- Working height of up to 14.8m
- Heavy duty trailer mounted articulated boom lift
- Superb and efficient engine for a smooth and accurate response
- Easy to use outrigger/boom safety interlocks
- Ideal for a wide range of applications

 **snorkel**[™]
www.snorkellifts.com

TRAILER MOUNTED BOOM LIFTS

MHP15HD

DIMENSIONS

	MHP15HD
Max. working height	14.8m
Max. platform height (A)	12.8m
Horizontal outreach	7m at 8m
Platform size	1.24m x 0.77m 1.1m
Outrigger footprint	3.7m x 3.6m
Overall width (outriggers extended)	3.7m
Overall width (outriggers retracted) (B)	1.77m
Overall length (C)	7.45m
Transport height (D)	1.9m

PERFORMANCE

Platform capacity	200kg
Max. wind speed	12.5m/s
Levelling	auto
Turntable rotation	540° non-continuous
Tyres	235/75 R15
Brakes	Hydraulic disc
Trailer tongue weight	90kg
Insulation rating	Nil

POWER

Power source	Honda petrol engine 5.5hp
Hydraulic system	Proportional live/hydraulic

WEIGHT

Gross weight	1,840kg
--------------	---------

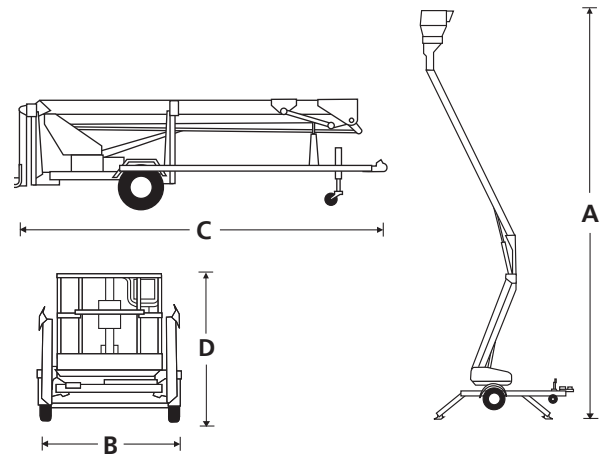

STANDARD FEATURES

- Two man steel platform
- Heavy duty tow coupling
- Heavy duty jockey wheel
- Hydraulic disc brakes
- Reliable petrol engine
- Platform rotator
- Automatic self-levelling stabilizers
- Hour meter
- Rotating basket mount

OPTIONS

- 10.9m height cut out switch
- Flashing light
- 110/240V AC GFCO power to platform
- Alternative power options
- Lifting lugs

WORKING ENVELOPE

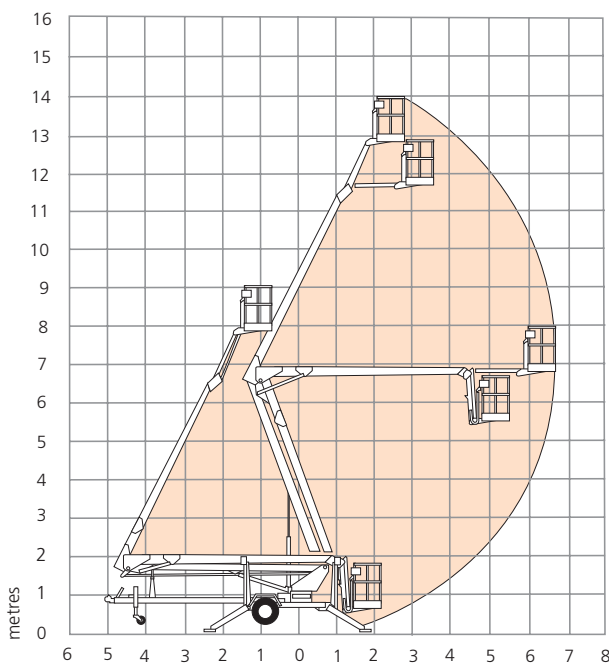

snorkel www.snorkellifts.com

Vigo Centre, Birtley Road,
Washington, Tyne & Wear,
NE38 9DA, U.K.

t: +44 (0) 845 1550 057
e: sales@snorkellifts.com